

# Pressure and Flow Relations in Vascular Bundles of the Tomato Plant

A. E. Dimond

Department of Plant Pathology and Botany,  
The Connecticut Agricultural Experiment Station, New Haven, Connecticut

Received April 30, 1965.

*Summary.* In the tomato plant water flows through primary xylem in accordance with Poiseuille's law. This relation and the analogy between Poiseuille's and Ohm's law were employed to calculate rates of flow and differences in pressure within vascular bundles when transpiration rates from individual leaves were known. The resistance of vascular bundles to flow was calculated from a modification of Poiseuille's law and from measurements of vessels in all bundles. The rates of flow in all bundles were derived from a set of simultaneous linear equations of flow, written to correspond with the nature of the vascular network. Values of the difference in pressure associated with flow in bundles were derived from resistances and flow rates in individual bundles. These agreed substantially with values observed in a comparable plant.

In large bundles, vessels occur in a frequency distribution that is approximately normal with respect either to the logarithms of their radii or to the fourth power of their radii. The largest vessels in a bundle transport most of the water when they are functioning.

The tomato plant contains 2 types of vascular bundle. The large bundles of the stem form a network by joining above each node in combinations of 2 at a time. The small bundles of the stem and petiolar bundles are independent of other bundles from their origins at junctions to their termini. The small bundles offer high resistance to flow, whereas the resistance of large bundles is low. The average conductance of large bundles decreases from the base to the apex of the stem. That of small vascular bundles remains low and more or less constant throughout the plant.

Only a small difference in pressure is required to maintain flow in large bundles. For lower leaves, the driving pressure required to move water to the base of a petiole is considerably less than that which moves water through petioles. The difference in pressure that maintains flow increases steadily for successively higher nodes. However, the pressure that drives flow to leaves is not always greater for higher leaves than for intermediate ones. For the plant examined, the highest leaves required a smaller amount of energy to move water from the ground than intermediate leaves did. This was also true of the power expended in moving water to individual leaves.

In the large network bundles, significant cross transfer of flow occurs at junction points from one bundle to another. Because of the interconnections between large bundles, pressure and flow relations are apparently not greatly altered when localized dysfunction occurs in the vessels of large bundles. In small, independent bundles, a localized dysfunction in vessels produces a significant effect on pressure and flow relations.

Water moves from one point to another at a rate that is proportional to the difference in potential and inversely proportional to the resistance to flow between these points. Gradmann (4), van den Honert (7), and Bonner (2) have each contributed to this concept, and recent studies on water movement in plant tissues reflect their ideas. This relation takes a form quite analogous to Ohm's law of the flow of electric current through a conductor. Even in the movement of water across layers of parenchymatous cells, where Rawlins (9) has shown that resistance cannot always be considered constant, the relation remains the same as van den Honert (7) proposed. These studies have all considered the movement of water through parenchymatous tissues of roots and leaves to be a steady state process, proceeding at a

rate that is equal to the rate of absorption from soil, of transport through vascular tissues, and of transpirational loss.

In xylem, transport of water occurs through a capillary system in which resistance to flow is much less than by alternative pathways between roots and transpiring tissues. Moreover, in xylem, resistance to flow is apparently constant over the range of flow rates that exist in the living plant (12, 18). In this simpler situation, flow occurs in response to a gradient in pressure, and the rate of flow is inversely proportional to the resistance that is characteristic of the pathway.

The present study considers the flow of water through vascular bundles of the tomato plant as a hydraulic process. The total flow through internodes

and petioles was determined from measurements of the rate of transpiration of individual leaves. The individual xylem bundles in the vascular system were identified and the resistance of each was calculated for an individual tomato plant from measurements of radii of vessels in each bundle, under the assumption that flow follows Poiseuille's law. Rates of flow through each bundle have been calculated from a set of simultaneous equations, based on the nature of the vascular network of bundles. In addition the difference in pressure required to move water at the rate it is transpired has been determined from the termini of petioles to the ground. Over portions of the pathway, calculated pressures have been compared with measured values, determined for these same rates of flow. The 2 sets of values agree substantially. Power consumption for water movement through xylem is estimated. Quantitative statements about rates of flow and pressure differences associated with flow in xylem bundles permit a better understanding of the process.

### Materials, Methods, and Measurements

*Nature of the Vascular Network.* The analysis of flow is based upon the characteristics of the vascular network. Ludwig (8) has described the primary vascular network of the tomato plant. Except for details of phyllotaxy, this system is similar to that of the potato, as described by Artschwager (1).

An internode contains 6 vascular bundles, 3 large ones that alternate with 3 small ones (fig 1A). One small bundle emerges from the stem as a central petiolar bundle at each node. Lateral petiolar bundles arise as branches from the 2 large bundles that lie on either side of the petiole. These branches arise below the node, usually in the upper internode. In the vicinity of the node, one of the large bundles branches successively. The major portion passes into the next internode. A minor branch forms the

small bundle that replaces the one emerging from the stem as a central petiolar bundle. Other branches constitute lateral petiolar bundles. The remaining branch connects, just above the node, with the second large bundle that lies on the opposite side of the petiole. The third large bundle passes through the node and in the next internode it forms the same types of branches, successively forming the small replacement bundle of the stem, the connecting branch to a large bundle, and lateral petiolar bundles.

The large bundles, therefore, constitute a network whereby 2 of them are interconnected in the vicinity of each node and all 3 participate equally in the network. The small bundles are not interconnected, but constitute independent pathways of flow from their origins as branches of large bundles to their termini in petioles. Thus, the 2 types of bundle, large and small, have different functions. At each node, bundles are displaced laterally. This displacement gives rise to the phyllotaxic pattern.

Analysis of the problem of flow is simplified if one ignores the lateral displacement of bundles at nodes and the precise locations where branches arise. The present study is based upon a model in which these factors are ignored and which also treats each group of lateral petiolar bundles as single bundles, one to the right and one to the left of the central bundle.

The model, and the vascular system itself, contain a repeated unit design. A portion of the model containing such a repeating unit is shown in figure 1B. The unit begins at the junction of bundles b and d, just above node 1, and extends to the next junction at node 4 (fig 1B). This unit includes bundle c and all petiolar bundles supplying leaf 4.

In the lower stem, only the upper portion of the repeating unit is represented. The large bundles join just above nodes 1, 2, and 3. These, and the small bundles, have common connections in the root, just below the transition region (6, 8, 16, 17). In the root, the xylem is exarch. Vessels in the upper root are contiguous. Through the transition region, the xylem divides into groups that emerge in the stem as vascular bundles.

The following conventions were adopted to identify vascular bundles. In any internode, the small bundles were designated as a, c, and e, whereas large bundles were designated as b, d, and f. A specific large bundle in internode 1 is designated as  $d_1$ , and a small one as  $c_1$ . The bundles of petioles were similarly identified, with the central bundles designated as y, the left hand lateral bundles as x, and the right hand lateral bundles as z. The small bundle of the stem,  $c_1$ , becomes  $y_1$ , whereas  $e_1$  extends into the next internode as bundle  $e_2$  and emerges in petiole 2 as  $y_2$  (fig 1B).

*Theory of Vascular Flow.* In the vascular system, flow of water is laminar rather than turbulent (18). Laminar flow in a capillary follows Poiseuille's law, which states that a driving pressure,  $p$ , is required to move a fluid with viscosity,  $\eta$ , at a rate of

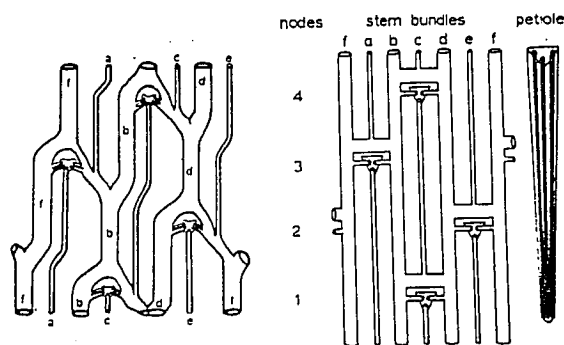

FIG. 1. Diagram of vascular bundles of lower tomato stem and petioles, shown as though the cylinder of the stem were unrolled to a flat plane. A, (left), Diagram showing displacement of bundles in vicinity of nodes and branching of large bundles. B, (right), Model employed in present study ignores displacement of bundles and considers lateral right and left hand group of petiolar bundles as though they were each single bundles.

$v$  ml per second through a capillary of radius  $r$  and length  $l$ , according to the relation

$$p = (8 l \eta v) / \pi r^4 \quad I$$

A vascular bundle contains many vessels. These are in parallel and their radii differ. As applied to such a bundle of capillaries, Poiseuille's law takes the modified form

$$p = (8 l \eta v) / \pi \Sigma (nr^4) \quad II$$

where

$$\Sigma(nr^4) = n_1 r_1^4 + n_2 r_2^4 + \dots + n_m r_m^4 \quad III$$

and  $n_1, n_2, n_3, \dots, n_m$  designate the number of vessels having radii of  $r_1, r_2, r_3, \dots, r_m$ .

The working relations expressed in equations (II) and (III) permit one to determine the difference in pressure,  $p$ , that exists at the ends of a vascular bundle of length,  $l$ , when water flows through it at a rate,  $v$ , and when values of  $\eta$  and  $\Sigma(nr^4)$  are known. Further, when allowance is made for branching of the bundles, one can compute the total difference in pressure necessary to raise water to leaves. Accordingly, these values were measured for a healthy tomato plant.

*Procedure.* The tomato plants (*Lycopersicon esculentum* Mill.) used in this study were of the Bonny Best variety, grown in sand in a greenhouse and fertilized with Hoagland's solution plus trace elements.

*Calculated Values of Rate of Flow and Pressure in the Vascular System.* The viscosity of tracheal fluid was measured with a viscosimeter. Samples were collected from decapitated plants, the first drops being discarded. This material had the same viscosity as water, viz., 0.01 poise at 20.2°.

All calculations are based on measurements of a healthy plant, bearing 16 leaves. Leaves and internodes were numbered, starting at the base of the plant. The first internode terminated at node 1. The length of each internode was measured to the nearest millimeter.

The objective of this study was to determine the pressure and flow relations in bundles when transpiration proceeds at a stated rate. Therefore, approximate measurements of the rates of transpiration of individual leaves suffice.

The transpiration rate of each leaf was estimated by measuring its rate of loss in weight when suspended from the arm of an analytical balance (3). This operation required no more than 60 seconds from the time when the leaf was removed from the plant. By this method, the estimated transpiration rate is considerably less than when leaves are supplied with water through the base of the petiole for a time prior to making the measurement (3). Leaves were removed in random order, one at a time, and the rate of loss in weight was determined on one before the next one was detached.

These data defined not only the transpiration rates of individual leaves, but also the rates at which

water moved through corresponding petioles. The rate of movement of water through an internode is the sum of the rates of transpiration of all leaves inserted above.

For each leaf, the center of area of leaf tissue was calculated from measured areas of leaves and tracings of leaf and petiole outlines. Petiole length was defined as the distance along the petiole from the node to the center of area of leaf tissue.

Determination of the value of the function  $\Sigma(nr^4)$  required a number of steps. Evaluation of this function, as defined in equation (III), requires that the frequency distribution of radii of functional vessels be determined in each vascular bundle within each internode and petiole throughout the plant. First, it was necessary to determine which vessels are functional in plants of age and size comparable to the plant on which measurements were to be made. A number of such plants were cut under water at the ground line and the cuttings were quickly transferred to dilute basic fuchsin solution. These were allowed to absorb the dye through the cut end for half an hour. Microscopic examination of thin, fresh cross sections, cut freehand from these plants, revealed that the walls of all vessels in vascular bundles were stained with dye, but that no vessels were stained in the developing secondary tissues outside of the bundles (10). Therefore, measurements of radii of vessels were limited to functional vessels, those contained in the vascular bundles.

A number of plants of comparable size and age were employed to determine the range of the radii of vessels, from the base of the stem to its apex. This was done by examining a number of thin, free-hand cross sections, cut from the first internode and from the apical internode and petiole. The largest and smallest vessels were located and these were measured with a calibrated ocular micrometer. A distribution of vessel radii having this range was then established, having class limits based upon equal increments of  $r^4$ .

A preliminary study had shown that the radii of vessels and also the value of  $\Sigma(nr^4)$  for a bundle vary along the axis of an internode or petiole. In order that measurements of these values be comparable from one sample to another, all measurements were made upon cross sections, cut from the center of an internode or petiole with respect to its longitudinal axis.

Measurement of radii of vessels was a time-consuming process. Until measurements were made on each internode and petiole, samples were preserved in a 2.5% solution of formaldehyde, which had previously been shown not to alter the radii of vessels in samples.

Finally, the identity of each vascular bundle had to be maintained throughout the process of dissection and measurement. This was done with the aid of 2 stripes of dye, one red and the other blue, applied side by side along the stem and each petiole. Sketches of the course of bundles and their position with re-

spect to the dye markers, before and after dissection, aided as well. The dye marks also aided in mounting cross sections on slides so that orientation was morphologically upward.

The experimental plant was dissected. Samples of each internode and petiole were labeled and preserved.

Samples were prepared for measurement, one at a time. A series of cross sections was cut from the central portion of the sample, normal to the longitudinal axis. These were mounted on a slide in their proper morphological orientation. One was selected for measurement and all bundles were identified by means of a diagram. For each bundle, the radii of all vessels were measured with a calibrated ocular micrometer. All internodes and petioles were examined in this manner.

**Calculations.** Vessels in each bundle were assigned to the appropriate class in the frequency distribution, and values of  $\Sigma (nr^4)$  were calculated by means of equation (III). This was done for the 6 bundles in each internode and the bundles in each petiole. Measurements from lateral petiolar bundles were pooled, so as to calculate a value of  $\Sigma (nr^4)$  for 1 bundle to the right and 1 to the left of the central bundle.

In order to simplify calculations, use was made of the analogy between Ohm's and Poiseuille's laws. A potential difference,  $E$ , across the terminals of a conductor is analogous to the difference in pressure,  $p$ , across the ends of a capillary system; the electrical current,  $I$ , is analogous to the rate of flow of fluid,  $v$ . The resistance of the conductor,  $R$ , is analogous to the composite term  $(8 l \eta) / \pi \Sigma (nr^4)$ .

When pressure is expressed in atmospheres, and rate of flow in ml per second, the resistance of a bundle to flow is given by the expression

$$R = (8 l \eta) / \pi C \Sigma (nr^4) = 2.51317 \times 10^{-8} l / \Sigma (nr^4) \quad \text{IV}$$

where  $C$  is the conversion factor from dynes per  $\text{cm}^2$  to atmospheres,  $1.01325 \times 10^6$  dynes per  $\text{cm}^2$  per atmosphere and  $\eta$  is the viscosity of the liquid contained in vessels,  $1.0 \times 10^{-2}$  poise at  $20.2^\circ$ .

The resistance between nodes or through a petiole of each vascular bundle was calculated by means of equation (IV) through use of the corresponding values of  $\Sigma (nr^4)$  and  $l$ .

With the above operations complete, analysis of the flow rates in individual bundles throughout the system could be undertaken. To facilitate and simplify the analysis, an electrical circuit diagram was drawn that was analogous to the entire vascular network. A portion of this diagram, corresponding to the repeating unit of the vascular system, is shown in figure 2.

Use of an electrical analogue for the hydraulic system involves a number of assumptions. First, one assumes that water can pass laterally from one vessel to another within a bundle. Such transfer is assumed to occur freely and to encounter little resist-

ance. Vessels constitute leaky tubes of considerable length. Especially in the case of annular, spiral, and scalariform elements, secondary thickening of the wall is absent over a high proportion of the surface. At points, the primary wall may be perforated where plasmodesmata existed when the cell was living. In a bundle, vessels are not separated from one another by xylem parenchyma along their whole length. Where vessels are contiguous, water may well pass from one element to another and net resistance to passage may be low because of the number of opportunities for passage. This will lead to a common pressure gradient for vessels within a bundle, over unit length.

Second, the pathways that constitute junctions between bundles are short and are assumed here to be negligibly low in resistance. Water is further assumed to pass through such junctions freely in either direction.

Third, each leaf is assumed to be at a uniform water potential, so that the pressure gradient in lateral petiolar bundles is the same from their origins in the vicinity of a node to their termini.

Subject to the foregoing assumptions, the pathway of flow (fig 2) from the junction at node 1 over  $b_2 + b_3 + b_4 + x_4$  is parallel with the pathways  $c_2 + c_3 + c_4 + y_4$  and  $d_2 + d_3 + d_4 + z_4$ . In addition, pathway  $b_2 + b_3 + b_4$  is parallel with  $d_2 + d_3 + d_4$ , and  $x_4$  is parallel with  $z_4$ . Comparable parallel pathways exist in the repeating unit associated with each node in the plant.

The network involving all the 16 internodes and petioles was considered as a whole. A series of independent, linear equations was written, embracing each unknown current in the individual conductors of the network. Additional equations defined the total rates of flow through petioles and internodes. This system of equations was solved simultaneously for the currents by the substitution method (19), employing essentially the procedure used for calculating unknown direct electric currents in conductors and making use of Ohm's and Kirchhoff's laws pertaining to electric circuits. For example, the following equations apply to the network shown in figure 2.

$$I_x R_x = I_z R_z$$

and

$$I_b (R_b + R_b) + I_b R_b + I_x R_x = I_c (R_c + R_c + R_c) + I_y R_y = I_d R_d + I_d (R_d + R_d) + I_z R_z$$

The loss in potential from point to point in the network was calculated just as  $IR$  drops are determined for individual conductors in an electric circuit. Here, appropriate values of rate of flow and resistance were employed for each vascular bundle. These products are equivalent to differences in pressure re-

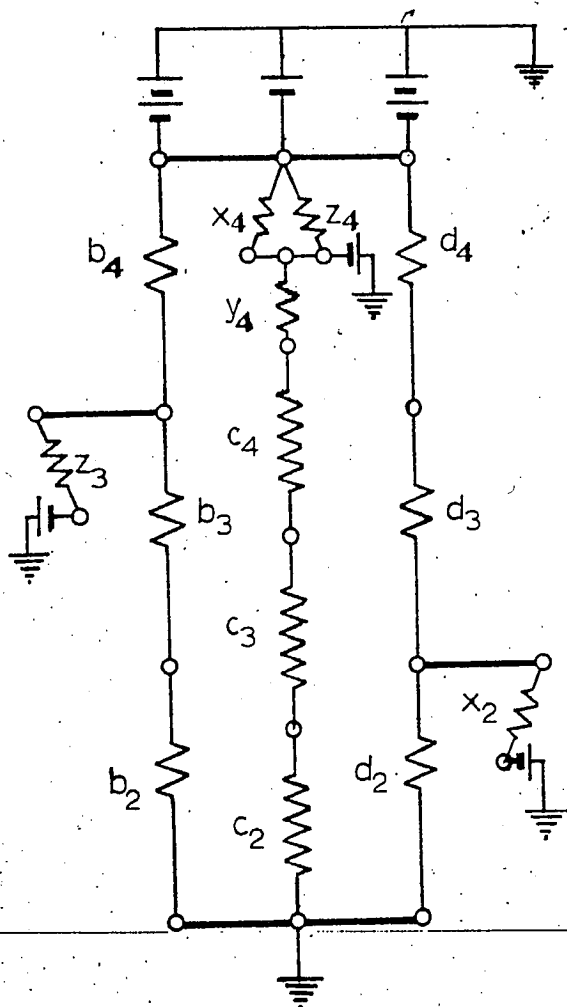

FIG. 2. Electrical circuit corresponding to the repeating unit of the vascular system of the tomato plant.

quired to move water at the stated rates through the bundles of internodes or petioles.

All calculations were carried to 6 decimal places to avoid errors arising when interpolated values are multiplied by large numbers. Entries in tables carry, in some cases, a large number of digits because the value of each entry depends upon the value of every other, as it must in a simultaneous solution. Reduction in number of digits in tabular entries will make impossible the cross checking and balancing of the values given for flow and pressure relations in the plant as a whole.

*Measured Rates of Flow Through Stems and Petioles at Known Differences in Pressure.* For purposes of comparison, the rates of flow through samples of stems and petioles were determined experimentally when a known difference in pressure was applied to the ends of the samples. The pressure applied to the input end of samples was always sufficiently low that flow through the bundles was laminar (18). The resulting relation of pressure to rate of flow, was em-

ployed to determine the difference in pressure required to move water through the sample at the rate of the transpiration stream. The experimentally determined differences in pressure were then compared with calculated values.

Plants of identical age and size comparable to the plant on which calculations were based were employed for these measurements. By methods already described, lengths of petioles and internodes were determined. Then leaf blades were removed, the stem and petiolar stubs remaining attached to the undisturbed root in its pot. When samples were to be removed, they were cut under water with a razor. The length of each sample was determined to the nearest millimeter. The initial samples were several internodes long with petiolar stubs attached. Later, individual internodes and petioles were employed as samples. All samples were from the same plant.

The flow meter consisted of 2 parts. The upper part consisted of a burette 1 cm in diameter, mounted vertically. It was tapered at the lower end to a diameter of 5 mm. Rubber tubing was attached to the lower end and a pinch clamp was used to close the tubing. The glass tube was filled with water to a measured height. The column of water provided a known head of pressure.

The lower end of the flow meter consisted of 1 mm heavy-walled glass tubing in the form of a tee that in turn was closely connected to a calibrated capillary pipette. The stem of the tee, constituting the side arm, was tapered at the tip. A tight-fitting rubber cap was placed over the tapered end. The capillary pipette readily measured volumes of water as low as 0.01 ml.

Submerged in water, the morphologically upper end of the sample was fitted by means of rubber tubing to the tee tube and capillary pipette. Connections were made so that they neither deformed the tissue by compression nor leaked. The morphologically lower end of the sample was similarly connected by rubber tubing to the bottom of the burette containing water. The sequence from top to bottom was burette, sample, tee tube, capillary pipette.

The rubber cap at the stem of the tee was pinched to introduce a small bubble of air into the vertical capillary tubing below the sample of tissue. The pinch clamp was removed at the base of the burette. Movement of the bubble through the capillary pipette was timed. This operation required only a few seconds per sample. All measurements were repeated. Unless the first 3 measurements were in close agreement, the sample was removed, the edges trimmed, connections were remade, and a new series of 3 measurements was taken. From the resulting data, rates of flow in ml per second were computed.

When samples consisted of several internodes of stem, the principal flow was through the stem, but small amounts of water were delivered through petiolar stubs as well. Only the flow through the morphologically upper end of the stem was measured in this case because this situation is analogous to the

considerable spiral, and ing of the the surface. rated where ; living. In one another role length. y well pass- ance to pass- r of oppor- a common bundle. over

the junction- d here to be further as- eily in either

t a uniform gradient in their origins

s, the path- node 1 over :hways  $c_2 +$  In addition,  $+ d_3 + d_4$ , arallel path- ed with each

ernodes and ries of inde- embracing l conductors defined the l internodes. nltaneously ethod (19), for calculat- 1 conductors f's laws per-, the follow- 1 in figure 2.

$$I_c (R_c +$$

+

nt in the net- e determined tric circuit. w and resist- ndle. These pressure re

one on which calculations were based. Measurements were made first for lengths of stem consisting of several internodes, and finally for samples consisting of individual internodes and petioles.

Rates of flow through samples were converted to correspond to the true lengths of petioles and internodes and the corresponding rates of flow in the intact plant at the location of the output end of the sample by means of the relation

$$p_a = (p_b l_a v_a) / (l_b v_b). \quad V$$

In this equation  $p_b$  is the applied pressure,  $v_b$  is the observed rate of flow in a sample of length  $l_b$  that corresponds to a true length,  $l_a$ , in the intact stem or petiole through which transpirational water flows at a rate,  $v_a$ , under a driving pressure of  $p_a$ . Values of  $v_a$  at various locations in the plant were determined from the data on the rates of transpiration of leaves. Values of  $p_a$  are here designated as measured or observed pressures.

### Results and Discussion

Lengths of vascular bundles were determined by the lengths of petioles and internodes. The total rate of water movement through petioles was given by the transpiration rates of leaves. The sum of the flow rates through all of the petioles above an internode defined the total rate of water transport through that internode (table I). Resistance of bundles to flow was determined from equation (IV) by substituting appropriate values of  $l$  from table I and the measured values of  $\Sigma(nr^4)$ . Values of the conductance of bundles, which is the reciprocal of resistance, or  $1/R$ , are given in table II.

Rates of flow through individual vascular bundles were calculated by solving the set of simultane-

ous equations describing flow in the entire vascular network. These are given in table III.

The difference in pressure required to move water through each large bundle was calculated from one junction to the next (table IV). Of the 2 large bundles forming a junction above a node, one passes through the next node independently and forms a junction again at the second node above. For this bundle, the difference in pressure was calculated for the interval of 2 internodes by multiplying the rate of flow through this bundle by the sum of the resistances in each internode. For example, bundle b joins with bundle d just above node 1 (fig 1B). Bundle b then passes directly through node 2 and is interconnected with bundle f just above node 3. The calculated rate of flow through  $b_2$  and  $b_3$  is  $371.45 \times 10^{-6}$  ml per second (table III). Calculated resistances of  $b_2$  and  $b_3$ , obtained from equation (IV) and data in table II, are 5.87 and 4.55 atm-sec per ml, respectively. The total calculated resistance is 10.42 atm-sec per ml. The drop in pressure associated with flow, then, is obtained from the product of rate of flow and resistance, or  $3.87 \times 10^{-3}$  atm. Corresponding values for other large vascular bundles are given in table IV.

Differences in pressure in small bundles were calculated similarly, with due allowance for pathways of flow (table IV). In the case of petiole 4, for example, lateral bundles  $x_4$  and  $z_4$  arise as lateral branches of bundles  $b_4$  and  $d_4$ , respectively (figs 1B, 2). Calculation of the drop in pressure associated with flow through these bundles is straightforward. However bundle  $y_4$  originates as bundle  $c_2$  at the junction of bundles b and d, just above node 1. This bundle passes through internodes 2, 3, and 4 and then emerges in the petiole as  $y_4$ . The difference in pressure reported is for the total path from its origin a-

Table I. Lengths of Internodes and Petioles and Rate of Flow of Water through Them in a Tomato Plant

Petiole or internode no.	Length		Rate of flow	
	Petiole	Internode	Petiole	Internode
			(ml/sec $\times 10^{-9}$ )	
1	8.0 cm	6.3 cm	8.7	1276.1
2	8.5	2.2	13.3	1267.4
3	10.3	1.7	33.2	1254.1
4	11.4	4.3	38.8	1220.9
5	11.4	4.0	66.1	1182.1
6	13.0	4.5	95.5	1116.0
7	11.3	6.0	75.3	1020.5
8	11.2	6.8	92.0	945.2
9	11.8	7.5	102.8	853.2
10	11.3	7.2	127.2	750.4
11	17.0	6.8	187.5	623.2
12	17.0	7.7	226.0	435.7
13	10.1	8.2	136.0	209.7
14	6.5	1.8	55.0	73.7
15	4.3	1.5	16.5	18.7
16	1.1	0.5	2.2	2.2

Table II. Conductance of Vascular Bundles (I/R)

Internode* or petiole no.	Internodal bundles						Petiolar bundles		
	a	b	c	d	e	f	x	y	z
	[(ml/sec-atm) × 10 <sup>-3</sup> ]								
1	0.455	23.451	0.046	107.203	0.084	41.704	0.056	0.050	0.042
2	0.192	170.201	1.686	253.640	0.591	180.793	0.074	0.050	0.064
3	6.741	219.969	0.370	396.936	1.320	295.482	0.252	0.073	0.222
4	1.420	177.390	0.811	117.634	0.384	96.261	0.193	0.053	0.245
5	0.983	106.674	3.136	147.580	1.554	160.182	0.992	0.171	0.213
6	1.664	91.268	0.320	134.288	1.861	106.185	0.861	0.391	0.520
7	1.434	53.815	0.275	84.004	1.744	88.763	0.463	0.231	0.608
8	2.514	80.479	0.964	109.762	0.344	52.403	0.643	0.153	0.293
9	1.322	60.341	0.312	38.724	1.406	13.607	0.226	0.066	0.804
10	1.053	26.596	0.683	57.554	0.968	36.013	0.974	0.112	0.930
11	1.157	64.878	2.174	22.306	0.411	17.240	1.125	0.211	0.651
12	1.836	20.751	2.720	14.458	2.072	10.196	0.914	0.228	0.679
13	1.372	13.683	0.562	16.498	4.682	7.637	1.248	0.411	1.571
14	2.082	4.145	2.572	3.701	2.524	1.408	0.413	0.354	0.301
15	1.369	2.774	0.292	0.623	2.226	1.955	1.022	1.007	0.754
16	0.080	0.844	0.446	1.218	0.016	0.079	0.004	0.065	0.083

\* Internode 2 begins at node 1 and terminates at node 2.

Table III. Rates of Flow through Vascular Bundles of Stem and Petioles

Internode* or petiole no.	Internodal bundle						Petiolar bundle			Origin of bundles x and z**
	a	b	c	d	e	f	x	y	z	
	(ml/sec × 10 <sup>-6</sup> )									
1	3.46	169.99	1.86	777.08	2.58	321.13	3.91	1.86	2.93	b-d
2	3.46	371.45	3.72	565.06	2.58	321.13	5.74	2.58	4.98	d-f
3	3.46	371.45	3.72	384.09	5.84	485.54	15.81	3.46	13.93	f-b
4	13.95	459.34	3.72	384.09	5.84	353.96	15.44	3.72	19.64	b-d
5	13.95	315.09	6.66	486.60	5.84	353.96	49.61	5.84	10.65	d-f
6	13.95	315.09	6.66	440.76	9.43	330.11	50.86	13.95	30.69	f-b
7	6.48	291.70	6.66	440.76	9.43	265.47	29.69	6.66	38.95	b-d
8	6.48	368.86	5.57	289.39	9.43	265.47	56.73	9.43	25.84	d-f
9	6.48	368.86	5.57	349.07	13.56	109.66	21.13	6.48	75.19	f-b
10	22.13	186.71	5.57	349.07	13.56	173.36	62.22	5.57	59.41	b-d
11	22.13	226.49	12.56	175.10	13.56	173.36	110.21	13.56	63.73	d-f
12	22.13	226.49	12.56	89.76	17.90	66.86	116.96	22.13	86.91	f-b
13	6.01	69.70	12.56	89.76	17.90	13.77	54.65	12.56	68.79	b-d
14	6.01	11.00	1.00	24.02	17.90	13.77	21.46	17.90	15.64	d-f
15	6.01	11.00	1.00	0.43	...	0.26	6.04	6.01	4.45	f-b
16	...	0.77	1.00	0.43	...	...	0.06	1.00	1.14	b-d

\* Internode 2 begins at node 1 and terminates at node 2.

\*\* Indicates point of origin of lateral petiolar bundles. The entry b-d indicates that bundle x arises as a branch from bundle b and bundle z arises from bundle d at this node.

bundle c<sub>2</sub> to its terminus in y<sub>4</sub>. In any given petiole the length of path for bundle y from its origin is greater than for bundles x and z. This accounts for the greater difference in pressure reported in table IV for central petiolar bundles, y, than for lateral ones (x and z).

Differences in pressure between any 2 points in the vascular system are additive over any direct pathway of flow, just as IR drops are additive in corresponding electric conductors in series. For example, water moves to the lateral bundles of petiole 4 by way of bundles b and d from the ground to node 4 and then via bundles x and z to their termini. The sum

of the pressure drops over either of these 2 pathways is the same. Thus, the successive pressure drops for the pathway via bundles b<sub>1</sub>, b<sub>2-3</sub>, b<sub>4</sub> and x<sub>4</sub> are (7.25, 3.87, 2.59, and 80.14) × 10<sup>-3</sup> atm. The second pathway is via bundles d<sub>1</sub>, d<sub>2</sub>, d<sub>3-4</sub>, and z<sub>4</sub> and the corresponding pressure drops are (7.25, 2.23, 4.23, and 80.14) × 10<sup>-3</sup> atm. The central petiolar bundle derives its water from either bundle b<sub>1</sub> or d<sub>1</sub> and, at the junction between them, water flows into the small bundle c<sub>2</sub> to y<sub>4</sub>. Over this pathway the pressure drops are (7.25 and 86.60) × 10<sup>-3</sup> atm. By any of these 3 pathways, the total difference in pressure from the ground line to the termini of petiolar bun-

vascular  
e water  
om one  
2 large  
passes  
orms a  
or this  
ted for  
he rate  
e resist-  
ndle b  
g 1B).  
and is  
3. The  
1.45 ×  
istances  
nd data  
respec-  
42 atm-  
ed with  
rate of  
Corres-  
dles are  
  
ere cal-  
athways  
4, for  
lateral  
figs 1B.  
sociated  
forward.  
at the  
l. This  
nd then  
in pres-  
rigin as  
  
Internode  
  
1276.1  
1267.4  
1254.1  
1220.9  
1182.1  
1116.0  
1020.5  
945.2  
853.2  
750.4  
623.2  
435.7  
209.7  
73.7  
18.7  
2.2

Table IV. Differences in Pressure Required to Move Water through Vascular Bundles at Rates Shown in Table III

Internode or petiole no.	Large bundle*			Small bundle		Total from ground	Origin of bundles ***	
	b	d	f	x and z	y**		x and z	y
	(atm $\times 10^{-3}$ )							
1	7.25	7.25	...	70.15	77.40	77.40	b-d	tr
2	...	2.23	9.48	77.10	86.58	86.58	d-f	tr
3	3.87	...	1.64	62.69	73.81	73.81	f-b	tr
4	2.59	4.23	...	80.14	86.60	93.85	b-d	c <sub>2</sub>
5	...	3.30	5.89	50.00	57.53	67.01	d-f	e <sub>3</sub>
6	6.41	...	3.11	59.05	68.05	79.17	f-b	a <sub>4</sub>
7	5.42	8.53	...	64.08	75.91	89.62	b-d	c <sub>5</sub>
8	...	2.64	8.06	88.27	99.44	116.45	d-f	e <sub>6</sub>
9	10.70	...	8.06	93.41	109.53	129.65	f-b	a <sub>7</sub>
10	7.02	15.08	...	63.86	81.58	107.12	b-d	c <sub>9</sub>
11	...	7.85	14.87	97.94	120.87	149.05	d-f	e <sub>10</sub>
12	14.41	...	6.56	128.01	149.44	185.68	f-b	a <sub>11</sub>
13	5.09	11.65	...	43.80	63.30	106.56	b-d	c <sub>11</sub>
14	...	6.49	11.58	51.93	70.07	121.18	d-f	e <sub>12</sub>
15	6.62	...	0.13	5.91	17.62	75.29	f-b	a <sub>13</sub>
16	0.92	1.05	...	13.71	21.25	84.01	b-d	c <sub>14</sub>

\* Values given for bundles b, d, and f are from one junction point to the next. Thus, for bundle b, the value  $7.25 \times 10^{-3}$  atm is the pressure difference from the ground line to the junction at node 1. The value  $3.87 \times 10^{-3}$  atm is the pressure difference between the junction at node 1 and the next junction at node 3.

\*\* Values given are for pressure difference over entire length of small bundle from origin at junction in stem 3 nodes below to terminus in petiole.

\*\*\* Bundles x and z originate as branches of designated large bundles at this node. Bundle y originates in transition region (tr) or at junction of large bundles in stem 3 nodes below. Thus bundle y of petiole 4 originates at junction of node 2 as bundle c<sub>2</sub>.

dles is the same,  $93.85 \times 10^{-3}$  atm (table IV). The differences in pressure required to move water from the ground to individual leaves, given in table IV, were obtained in this manner. The predicted pressure differences over several internodes, reported in table V, were obtained similarly.

In order to test the validity of the calculated values, the difference in pressure was also measured experimentally on a different but comparable plant. Under a low head of pressure, the rate of flow of water was measured through lengths of stem and petioles. These data were corrected by means of equation (V) to correspond to the pressure required to maintain flow at the rate of movement of the transpiration stream in the plant upon which calculations were based. The resulting, observed values of pressure are compared with the predicted, or calculated pressure differences in table V.

Considering the nature of the comparison, the observed and predicted values agree reasonably well. The comparison is necessarily based upon values obtained from different plants, in which the conductances of the corresponding internodes and petioles differ.

The observed and predicted values of difference in pressure are in substantial agreement. This suggests that the assumptions and theory upon which calculations are based lead to a reasonable estimate of the true values. On this basis, predicted or calculated values can be used to infer additional properties of the transport system.

*Conductance of Vascular Bundles.* The conductance of a bundle is the reciprocal of its resistance to flow. Conductance is the rate of flow through a bundle under unit difference in pressure, and is reported in table II in units of ml per second under a difference in pressure of 1 atm.

The conductance of an unbranched bundle varies from one internode to the next. For example, bundle d varied in conductance from about 120 to  $400 \times 10^{-3}$  ml per sec-atm between nodes 2 and 4. This

Table V. Observed and Predicted Pressures Required for Flow through Xylem of Stem and Petioles at Rate of the Transpiration Stream

Internode or petiole no.	Internodes		Petioles	
	Predicted	Observed	Predicted	Observed
	(atm $\times 10^{-3}$ )			
1	7.3	10.6	70.1	68.5
2	2.2	1.9	77.1	...
3	1.6	1.1	62.7	98.5
4	2.6	2.4	80.1	80.0
5	3.3	2.2	50.0	80.3
6	3.1	2.1	59.1	62.5
7	5.4	2.3	64.1	73.4
8	2.6	2.8	88.3	57.2
1-3	11.1	10.8		
4-5	5.9	6.1		
1-6	20.1	22.7		
7-8	8.1	8.0		
7-11	31.0	24.0		



variation is normal and reflects the variation in size and number of vessels along a bundle. The 3 large bundles traversing an internode may differ in size and their conductance reflects this difference. For example, in the first internode, the conductance of bundles, b, d, and f was approximately 23, 107, and  $42 \times 10^{-3}$  ml per sec-atm, respectively.

In the lower stem, the conductance of large bundles b, d, and f ranged from 50 to 100 times greater than of small stem bundles a, c, and e. However, the large network bundles decrease in size from the base to the apex of the stem, whereas small bundles of the stem and petiolar bundles remain of approximately the same size throughout the plant. In the upper stem, conductance of large and small bundles is similar.

Change in conductance of bundles in different parts of the plant reflects their change in size. For example, the average conductance of the 3 large bundles in internodes 3, 6, 9, 12, and 15 was approximately 304, 111, 38, 15, and  $1.8 \times 10^{-3}$  ml per sec-atm, respectively. By contrast, the average conductance of small bundles in the stem, with the exception of those in the first and sixteenth internodes, was  $1.5 \times 10^{-3}$  ml per sec-atm. For the first and sixteenth internodes, average conductance was, respectively, 0.20 and  $0.18 \times 10^{-3}$  ml per sec-atm.

The first 2 leaves to develop on the plant have a small area and a low transpiration rate. Bundles in the first 2 petioles are also small. The calculated conductance of petiolar bundles in the 2 oldest leaves was low in comparison with other petiolar bundles. In the first leaf, the petiole contains but 1 lateral bundle on either side of the median bundle.

In higher petioles, the apparently higher conductance of bundles x and z than of the median bundle is not significant, but results from the procedure of pooling vessel measurements in groups of lateral bundles. Bundle x, for example consisted in reality of 2 or more bundles to the left of the median bundle. Therefore, although the values reported in table II accurately indicate the conductance of the right or left hand group of lateral petiolar bundles, the individual bundles of the group have a conductance that is similar to that of the median bundle. The method of calculating resistance of lateral petiolar bundles has allowed for the parallel pathways of flow through the groups of lateral petiolar bundles.

*Radii of Vessels in Relation to Flow in a Bundle.* As equation (III) indicates, the function  $\Sigma (nr^4)$  depends upon the nature of the frequency distribution of radii of vessels in a vascular bundle. The nature of this frequency distribution was examined. The population in any one bundle is too small a sample to describe the characteristics of the distribution accurately. To obtain a larger population, a group of 8 large vascular bundles was selected, having an average of 81 vessels per bundle. This group contained a total of 650 vessels. The bundles in this group had comparable values of  $\Sigma (nr^4)$ , and comparable ranges and means with respect to vessel radius. In this

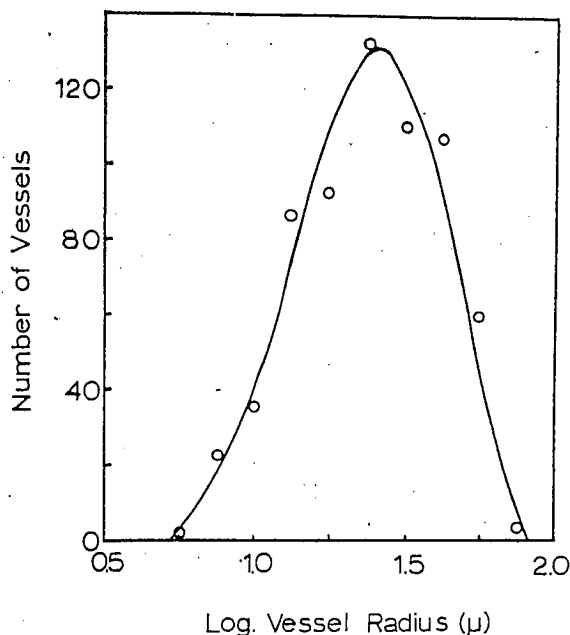

FIG. 3. Frequency distribution of vessels in a large vascular bundle of the tomato plant.

population, when the number of vessels in each class was plotted against the logarithm of the radius, the resulting frequency distribution was approximately normal and symmetrical (fig 3). The frequency distribution was also symmetrical and approximately normal when the number of vessels in each class was plotted against the corresponding values of  $r^4$ .

The relative contribution of vessels of differing radii to the flow through a vascular bundle can be calculated. When a difference in pressure exists across the ends of a bundle of capillaries, the flow rate in each is proportional to the fourth power of its radius. A vascular bundle is such a bundle of capillaries. In the large vascular bundles examined, the largest vessels had radii more than 10 times as great as the smallest. When each is subjected to the same difference in pressure, the largest vessel should transport water at more than 10,000 times the rate of the smallest ones. In a typical large vascular bundle, vessels were grouped in classes according to their radii, and the relative conduction was calculated for each group (table VI). The single largest vessel in the bundle should conduct about 23% of the water transported by the entire bundle per unit of time. The 6 largest vessels should transport about 60% of the water moving through the bundle per unit of time, whereas the 10 smallest vessels should transport about 0.05% of the total.

However, the significance of vessel radius is dual, and herein lies the importance of range in size and of the nature of the frequency distribution of vessel radii as a characteristic of the bundle. When all vessels are functional, the large vessels transport

y  
tr  
tr  
tr  
c<sub>2</sub>  
e<sub>3</sub>  
a<sub>4</sub>  
c<sub>5</sub>  
e<sub>6</sub>  
a<sub>7</sub>  
c<sub>8</sub>  
e<sub>9</sub>  
a<sub>10</sub>  
c<sub>11</sub>  
e<sub>12</sub>  
a<sub>13</sub>  
c<sub>14</sub>  
le 7.25  
-3 atm  
nodes  
nsition  
t junc-  
nduct-  
nce to  
ugh a  
is re-  
under  
varies  
: bun-  
400 X  
This  
equired  
les  
s  
bserved  
68.5  
...  
98.5  
80.0  
80.3  
62.5  
73.4  
57.2

Table VI. *Distribution of Vessel Sizes in a Bundle and Their Relative Conductive Capacities*

Avg. radius* ( $\mu$ )	No. ( $n$ )	Conductive capacity ( $nr^4$ )	% Relative conduction
5.62	1	1000	0.00
7.50	4	12,640	0.01
10.0	5	50,000	0.04
13.3	12	379,200	0.28
17.8	12	1,200,000	0.89
23.7	19	6,004,000	4.49
31.6	13	13,000,000	9.71
42.2	10	31,600,000	23.61
56.2	5	50,000,000	37.36
75.0	1	31,600,000	23.61
Totals	82	133,846,840	100.00

\* Class limits are given by the fourth root of the geometric mean of successive pairs of values of  $r^4$ , or  $(1000 \times 3160)^{1/8}$ ,  $(3160 \times 10,000)^{1/8}$ , etc.

water and offer relatively little resistance to flow. When small vessels cease functioning, the impact on water economy of the plant is small. However, liquid in large vessels is more subject to fracture than in small ones (11, 13) and restitution of water columns in large vessels is slow (13). When large vessels become dysfunctional, the small vessels and tracheids assume the important function of maintaining continuous water columns. This has been well demonstrated by Greenidge (5) in experiments on stems with overlapping partial cuts and by Scholander et al. (11, 13, 14, 15). These experiments all attest to the essential function of small vessels, tracheids, and pit membranes in maintaining the continuity of water in the fine capillaries when water stress is high and water columns break in large vessels. The fine capillaries offer high resistance to flow but water columns are stable, mechanically. When the plant is not under stress and the large vessels are functional, they offer an efficient, low resistance circuit. When the stem is cut, wounded, frozen, or diseased, the very fine capillary system continues to function as a high resistance circuit.

*Relations of Flow between Vascular Bundles.* The equations describing rates of flow in vascular bundles must fulfill a number of conditions. The sum of the rates of flow in the bundles of an internode must equal the sum of the rates of transpiration of leaves inserted on the stem above this internode. The sum of the rates of flow through bundles traversing a petiole must equal the rate of transpiration of the leaf. The rate of flow through a bundle must be constant from its origin to the point where it joins another bundle or terminates. The sum of the flow rates meeting at any point is zero. Two bundles are in parallel from one junction to their next junction. At junction points, the rates of flow are redistributed among bundles in such a manner that the drop in potential is equal over any of the parallel pathways.

Rates of flow through bundles may change greatly or only slightly at a junction, depending upon the resistances of the bundles and the lengths of the path between junctions. An illustration is the redistribution occurring between bundles b and d from the first to the second internode (table III and fig 4). Bundle b carries water through the first internode at a rate that supplies the left lateral petiolar bundle of leaf 1 and a portion of the flow for bundle b in internode 2. The balance is transferred at the junction from bundle d, which also supplies the flow for bundle c in internode 2. By this cross transfer, the rate of flow in bundle b is more than doubled from the first to the second internode. Similarly, a cross-transfer of flow occurs at the junction just above node 2 from bundle d to bundles e and f in internode 3. A transfer of flow should occur in like manner at each junction.

Because of the junctions, distribution of flow may alter rapidly as localized demand for water is temporarily or locally created by variation in the rate of transpiration or by wounding. The efficiency of the vascular network in adjusting to suddenly imposed changes in water demand can be illustrated by experiments of Ludwig (8) and of Dimond and Waggoner (3). When all but one large vascular bundle in the stem of a well-watered tomato plant were severed by notching, no tissue wilted, even on a sunny day, excepting the tissue supplied by the 3 central petiolar bundles that were extensions of the severed small vascular bundles of the stem. No alternate pathway exists for movement of water to the tissues that wilted. The remaining leaves and portions of leaves remained turgid because of the redistribution of flow rates across junctions in the network.

*Pressure Differences and Energy Associated with Flow in Vascular Bundles.* Frictional losses occur when water moves through a system of capillaries. This requires energy in the form of a difference in pressure from one end of the system to the other. The amount of energy and the equivalent difference in pressure depend on the rate of flow. The differences in pressure associated with flow through individual bundles have been calculated (table IV and fig 5). Flow through large bundles in the stem requires a relatively small amount of energy. The calculated differences in pressure between junction points of these bundles are low. For petiolar bundles, the pressure differences are considerably higher.

Apart from energy associated with lifting water, the energy associated with flow from the ground to individual leaves can be estimated as the sum of the differences in pressure that move water via large bundles through successive internodes and via small bundles through the petiole. This is analogous to the flow of direct current through an electrical circuit, where the total electromotive force is equal to the sum of the drops in potential over the individual resistances that comprise the circuit.

The differences in pressure associated with flow

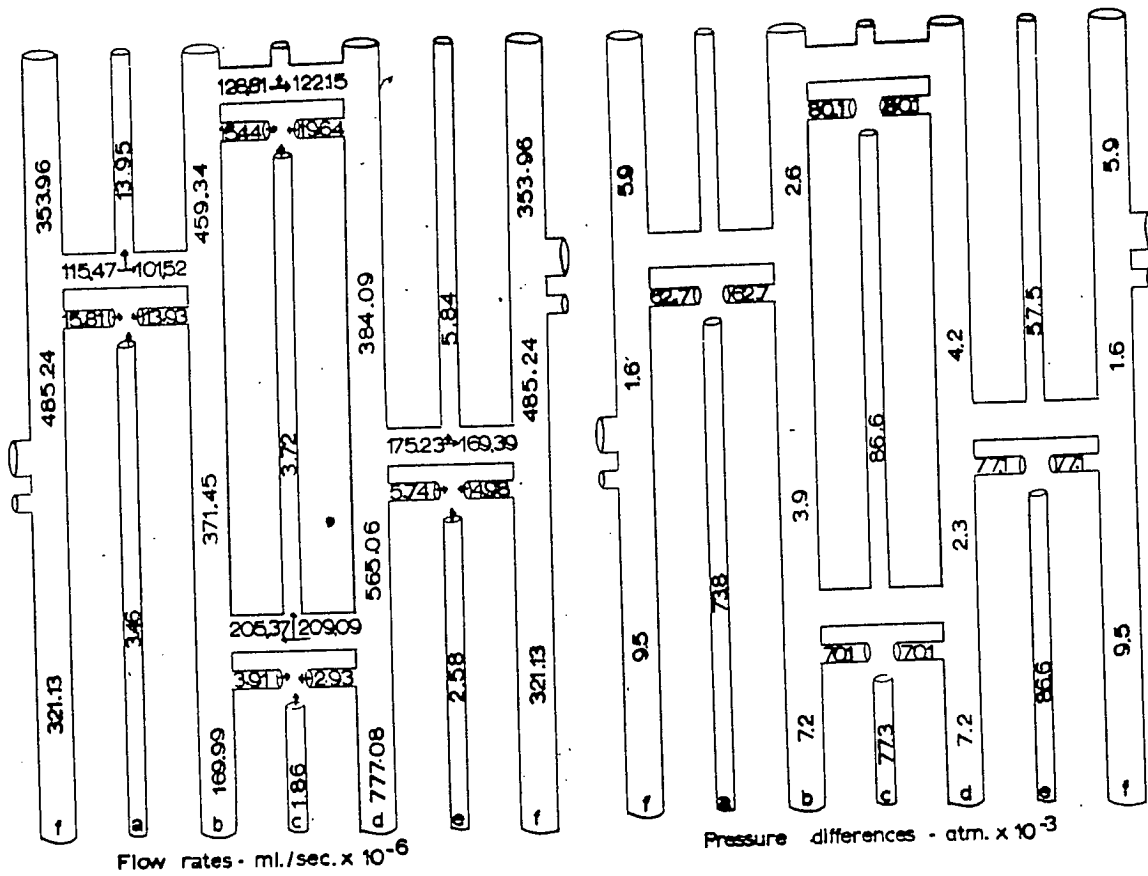

FIG. 4. Rates of flow through vascular bundles of the lower stem and petioles.  
 FIG. 5. Differences in pressure required to maintain flow rates through bundles of the lower stem and petioles.

from the ground to nodes and through petioles to individual leaves have been calculated (table IV). For lower leaves, the difference in pressure associated with flow from the ground to a node has been calculated to be considerably less than that necessary to move water through the petiole inserted at this node. At higher nodes, cumulative pressure differences in the stem eventually equal or exceed the pressures necessary to drive water through petioles.

The pressure required to drive water through bundles increases for successively higher nodes and is a maximum at the apex of the stem. These pressures are approximately the sums of the pressures required to move water through large bundles between junction points at successive nodes (table IV). Such values for nodes 3, 6, 9, 12, and 15 are, respectively 11.12, 20.12, 36.24, 57.67, and 69.38 × 10<sup>-3</sup> atm. However, the pressure required to move water from the ground through petioles to leaf tissue does not increase regularly with height. In fact, for some of the highest leaves, less pressure is required than for some of the intermediate ones (tables IV, VII). This results from variation in transpiration rate, and the characteristics of vascular bundles in the stem and in individual petioles over the route of the transpiration stream.

Energy is also required to lift water in the erect stem. This also can be expressed as a difference in pressure from point to point, which increases regularly with height along the stem (table VII). The total energy to lift water against the force of gravity and to move it through the stem is the sum of these two. Contrary to what one might expect, this total difference in pressure in the tomato plant does not increase regularly with height. It is a maximum for intermediate leaves, not apical ones (table VII, sum of entries in columns 2 and 3). The energy for both processes is indirectly derived from that associated with evaporation of water, derived from transpiration.

The power expended in these processes can be estimated from the rate of work, the product of the total pressure and rate of flow (table VII). The calculated power expended on lifting and flow of water to leaves is a maximum for intermediate leaves, just as the driving pressure is. Thus, the power consumed in lifting and moving water to the fifteenth leaf was less than one-tenth of that required for the eleventh leaf. For the plant as a whole, total power consumption is small, some 220 ergs per second.

This approach to pressure and flow relations in the vascular system is consistent with the measure-

ge greatly upon the is of the the redi- from the id fig 4). ternode at ar bundle indle b in the junc- e flow for nsfer, the bled from ly, a cross just above ternode 3. manner at

flow may is tempor- he rate of iciency of ddenly im- strated by imond and e vascular nato plant . even on a . by the 3 ions of the m. No al- rater to the s and por- f the redi- in the net-

ociated with oses occur capillaries. iffERENCE in o the other. t difference The differ- through in- ble IV and n the stem nergy. The en junction petiolar bun- rably higher. fting water. e ground to : sum of the er via large nd via small analogous to electrical cir- e is equal to he individual ed with flow

Table VII. *Driving Pressure and Power Expended in Raising Water to Leaves*

Leaf	Pressure for flow lifting (atm)		Flow rate (ml/sec)	Power expended (ergs/sec)	
	( $\times 10^{-3}$ )	( $\times 10^{-3}$ )		flow	total
1	77.40	6.10	8.7	0.68	0.73
2	86.58	8.23	13.3	1.17	1.28
3	73.81	9.87	33.2	2.48	2.82
4	93.85	14.03	38.8	3.69	4.24
5	67.01	17.91	66.1	4.49	5.69
6	79.17	22.26	95.5	7.66	9.82
7	89.62	28.07	75.3	6.84	8.98
8	116.45	34.65	92.0	11.70	14.93
9	129.65	41.91	102.8	13.50	17.87
10	107.12	48.88	127.2	13.81	20.10
11	149.05	55.46	187.5	28.32	38.85
12	185.68	62.91	226.0	42.52	56.92
13	106.56	70.85	136.0	14.68	24.45
14	121.18	72.59	55.0	6.75	10.80
15	75.29	74.04	16.5	1.26	2.50
16	84.00	74.52	2.2	0.19	0.35
Total power expended				220.33	

ments on sap pressure in vascular plants and the concepts developed by Scholander et al. (12). The values measured by them are in absolute terms, whereas those reported here are not. Instead they are reported as differences in pressure from one location to another in the plant. The negative pressures measured by Scholander et al. include the requirements for overcoming turgor effects and flow of water across layers of parenchymatous cells. In the present study, the calculated differences in pressure are merely those associated with vascular bundles, the transport system itself. The energy associated with movement through the transport system is small by comparison with that required for movement through parenchymatous tissues of leaves and roots. Furthermore, tomato plants are short and the energy required for lifting water in them is small compared with the requirements for lifting water in tall trees. The tomato plant has no unusual solute relations that require expenditure of energy for movement of relatively pure water across a layer of solute-rich cells, such as the halophytes do. The data of Scholander et al. (12) indicate that the total energy associated with lifting water and its movement through parenchyma of leaves is greater than that associated with flow through the capillary vascular system, especially in tall trees and halophytes. Nothing in the present study is in conflict with this finding.

*Effect of the Network on Pressure and Flow Relations in Large Bundles.* Two kinds of bundles exist in the vascular system; the large bundles, which are interconnected, and the small ones, which are not. The method of analysis employed for the normal plant can be used to evaluate the effect of the network on pressure and flow relations.

The following analysis, admittedly an artificial condition, is based on the assumption that every vessel in a vascular bundle is reduced to half of its normal radius by an obstruction. This condition changes the value of  $\Sigma(nr^4)$  to one-sixteenth of its original value. In this circumstance, the pressure and flow relations, defined in equation (II), are changed drastically in the affected bundle. If the difference in pressure across the ends of the bundle does not change, the rate of flow should drop to one-sixteenth of its original value. If the flow is to remain the same, the difference in pressure must increase 16-fold. These conditions apply to petiolar bundles and small bundles in the stem. They also apply to the affected large bundle between junction points.

The effect of such a condition in a network bundle was also examined. In this case, the value of  $\Sigma(nr^4)$  for bundle f was assumed to be one-sixteenth of its original value in internodes 1 and 2 but to be unaffected elsewhere, and all other bundles were assumed to have their original values. These values were substituted in the set of equations and new values of flow rate were calculated on the assumption that the total rate of flow to leaves remained unchanged. Less water should flow through bundle f in internodes 1 and 2, but flow rates should increase correspondingly in bundles b and d in these internodes. Calculated new values indicate that the interchange of water at junctions between large bundles in the lower stem was greatly increased. From the fifth internode upward, rates of flow in all bundles was approximately the same as in the normal plant. Rates of transport through petiolar bundles were little-affected.

Driving pressures were calculated for bundles under this assumed condition. The increase in pressure necessary to maintain flow at an unaltered total rate proved to be very small. The maximum calculated increase at any point was 4.5% and in most of the system, the increase was less. That in an experimental plant, severance of a large bundle in the stem by notching leads to no important result, whereas severance of a small bundle produces wilting of the tissues it supplies (3, 8), suggests that the calculated result is a valid approximation to the pressure and flow relations in independent and in network bundles.

#### Literature Cited

- ARTSCHWAGER, E. F. 1918 Anatomy of the potato plant with special reference to the ontogeny of the vascular system. *J. Agr. Research* 14: 221-52.
- BONNER, J. 1959. Water transport. *Science* 129: 447-50.
- DIMOND, A. E. AND P. E. WAGGONER. 1953. The water economy of *Fusarium*-wilted tomato plants. *Phytopathology* 43: 619-23.
- GRADMANN, H. 1928. Untersuchungen über die Wasserverhältnisse des Bodens als Grundlage des Pflanzenwachstums. *Jahrb. Wiss. Botan.* 69: 1-100.

5. GREENIDGE, K. N. H. 1958. Rates and patterns of moisture movement in trees. In: *The Physiology of Forest Trees*. K. V. Thimann, ed. Ronald Press, New York. p 19-42.
6. HAYWARD, H. E. 1938. *The Structure of Economic Plants*. Macmillan, New York. p 571-73.
7. HONERT, VAN DEN, T. H. 1948. Water transport in plants as a catenary process. *Discussions Faraday Soc.* 3: 146-53.
8. LUDWIG, R. A. 1952. Studies on the physiology of hadromycotic wilting in the tomato plant. *Macdonald Coll. Tech. Bull. Montreal.* 20: 40 p.
9. RAWLINS, S. 1963. Resistance to water flow in the transpiration stream. In: *Stomata and Water Relations in Plants*. I. Zelitch, ed. Conn. Agr. Expt. Sta. Bull. New Haven. 664: p 69-85.
10. SAALTINK, G. J. AND A. E. DIMOND. 1964. Nature of plugging material in xylem and its relation to rate of water flow in *Fusarium* infected tomato stems. *Phytopathology* 54: 1137-40.
11. SCHOLANDER, P. F. 1958. The rise of sap in lianas. In: *Physiology of Forest Trees*. K. V. Thimann, ed. Ronald Press, New York. p 3-17.
12. SCHOLANDER, P. F., H. T. HAMMEL, Ed. D. BRADSTREET, AND E. A. HEMMINGSEN. 1965. Sap pressure in vascular plants. *Science* 148: 339-46.
13. SCHOLANDER, P. F., E. HEMMINGSEN, AND W. GAREY. 1961. Cohesive lift of sap in the rattan vine. *Science* 134: 1835-38.
14. SCHOLANDER, P. F., W. E. LOVE, AND J. W. KANWISHER. 1955. The rise of sap in tall grapevines. *Plant Physiol.* 30: 93-104.
15. SCHOLANDER, P. F., B. RUDD, AND H. LEIVESTAD. 1957. The rise of sap in a tropical liana. *Plant Physiol.* 32: 1-6.
16. THIEL, A. F. 1931. Anatomy of the primary axis of *Solanum melongena*. *Botan. Gaz.* 92: 407-19.
17. THIEL, A. F. 1933. Vascular anatomy of the transition region of certain *Solanaceous* plants. *Botan. Gaz.* 94: 598-604.
18. WAGGONER, P. E. AND A. E. DIMOND. 1954. Reduction in water flow by mycelium in vessels. *Am. J. Botany* 41: 637-40.
19. WILLIERS, F. A. 1948. *Practical Analysis*. Dover Publications, New York. p 265-67.

artificial  
ery ves-  
its nor-  
changes  
original  
nd flow  
ed dras-  
rence in  
oes not  
sixteenth  
nain the  
ease 16-  
bundles  
ly to the  
s.  
ork bun-  
dles of  $\Sigma$   
sixteenth  
out to be  
were as-  
e values  
and new  
sumption  
ined un-  
bundle f  
l increase  
ese inter-  
the inter-  
e bundles  
From the  
ll bundles  
nal plant.  
lles were

r bundles  
e in pres-  
ered total  
calculated  
ost of the  
in experi-  
n the stem  
; whereas  
ing of the  
calculated  
essure and  
rk bundles.

i the potato  
geny of the  
t: 221-52.  
cience 129:

1953. The  
mato plants.

n über die  
undlage des  
tan. 69: 1-